

# TURBOGRAF

## SEAL SYSTEMS

A RELIABLE AND  
COST-EFFECTIVE SOLUTION

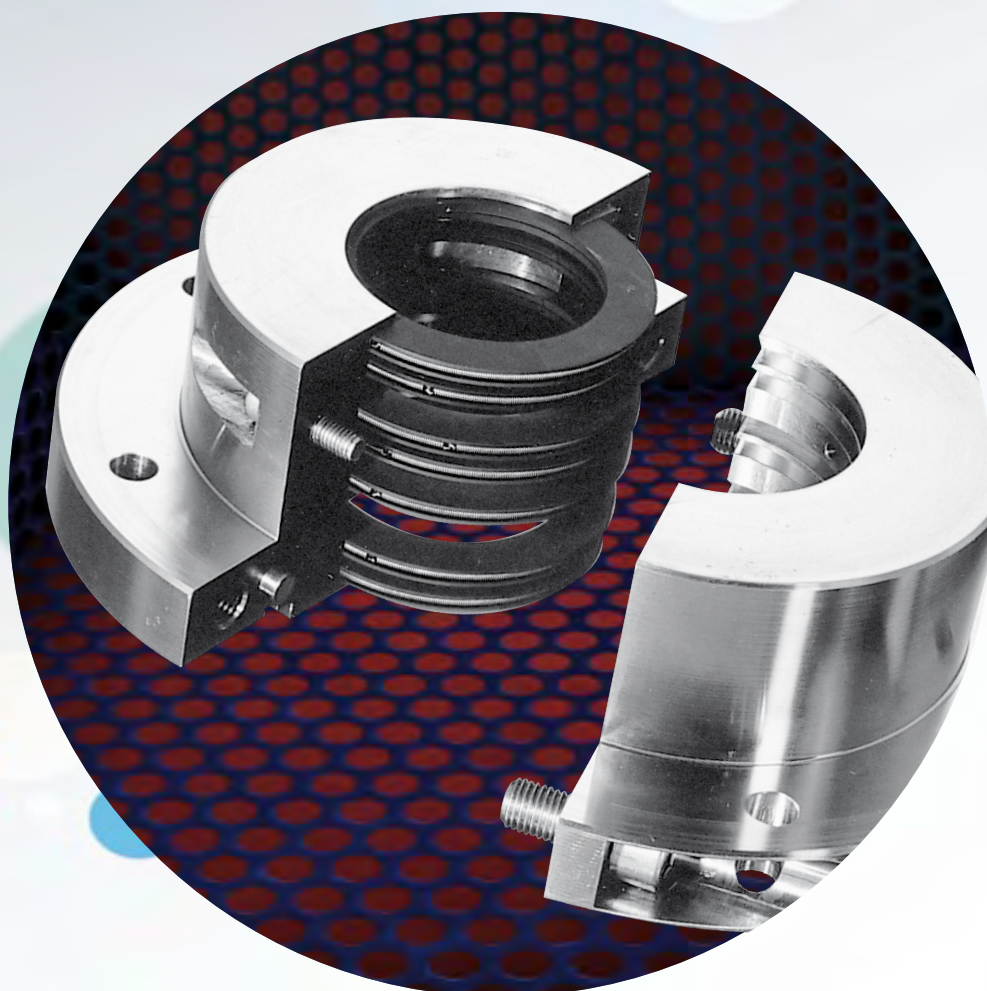

Архангельск (8182)63-90-72  
Астана (7172)727-132  
Астрахань (8512)99-46-04  
Барнаул (3852)73-04-60  
Белгород (4722)40-23-64  
Брянск (4832)59-03-52  
Владивосток (423)249-28-31  
Волгоград (844)278-03-48  
Вологда (8172)26-41-59  
Воронеж (473)204-51-73  
Екатеринбург (343)384-55-89  
Иваново (4932)77-34-06

Ижевск (3412)26-03-58  
Иркутск (395)279-98-46  
Казань (843)206-01-48  
Калининград (4012)72-03-81  
Калуга (4842)92-23-67  
Кемерово (3842)65-04-62  
Киров (8332)68-02-04  
Краснодар (861)203-40-90  
Красноярск (391)204-63-61  
Курск (4712)77-13-04  
Липецк (4742)52-20-81

Магнитогорск (3519)55-03-13  
Москва (495)268-04-70  
Мурманск (8152)59-64-93  
Набережные Челны (8552)20-53-41  
Нижний Новгород (831)429-08-12  
Новокузнецк (3843)20-46-81  
Новосибирск (383)227-86-73  
Омск (3812)21-46-40  
Орел (4862)44-53-42  
Оренбург (3532)37-68-04  
Пенза (8412)22-31-16

Пермь (342)205-81-47  
Ростов-на-Дону (863)308-18-15  
Рязань (4912)46-61-64  
Самара (846)206-03-16  
Санкт-Петербург (812)309-46-40  
Саратов (845)249-38-78  
Севастополь (8692)22-31-93  
Симферополь (3652)67-13-56  
Смоленск (4812)29-41-54  
Сочи (862)225-72-31  
Ставрополь (8652)20-65-13

Сургут (3462)77-98-35  
Тверь (4822)63-31-35  
Томск (3822)98-41-53  
Тула (4872)74-02-29  
Тюмень (3452)66-21-18  
Ульяновск (8422)24-23-59  
Уфа (347)229-48-12  
Хабаровск (4212)92-98-04  
Челябинск (351)202-03-61  
Череповец (8202)49-02-64  
Ярославль (4852)69-52-93

Киргизия (996)312-96-26-47

Россия (495)268-04-70

Казахстан (772)734-952-31

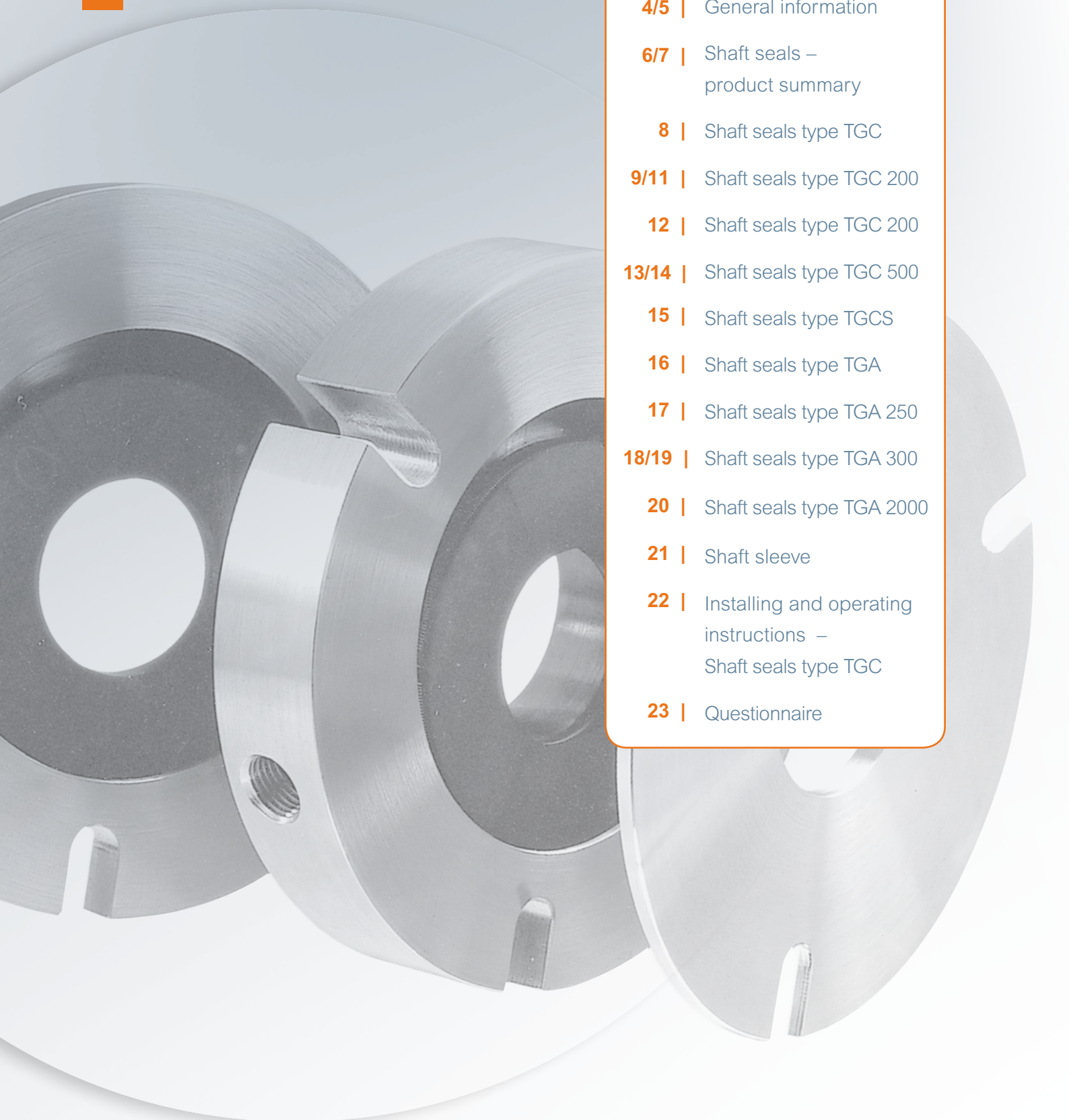

<b>4/5</b>		General information
<b>6/7</b>		Shaft seals – product summary
<b>8</b>		Shaft seals type TGC
<b>9/11</b>		Shaft seals type TGC 200
<b>12</b>		Shaft seals type TGC 200
<b>13/14</b>		Shaft seals type TGC 500
<b>15</b>		Shaft seals type TGCS
<b>16</b>		Shaft seals type TGA
<b>17</b>		Shaft seals type TGA 250
<b>18/19</b>		Shaft seals type TGA 300
<b>20</b>		Shaft seals type TGA 2000
<b>21</b>		Shaft sleeve
<b>22</b>		Installing and operating instructions – Shaft seals type TGC
<b>23</b>		Questionnaire

# GENERAL INFORMATION

## A LEADING COMPANY'S EXPERIENCE

### CERTIFICATION TO ISO 9001-2008 : 2010

Both official bodies and our clients have recognised our quality management. The TÜV has authorised MERSEN to issue materials testing certificates. MERSEN is also an approved defence industry contractor.

MERSEN is one of the few companies which makes its own materials. For a century now, we have been making fine and ultra-fine structure graphite products. By constantly monitoring the total production process, MERSEN has all the technical problems completely in hand.

MERSEN's graphite products are unrivalled on the market, and are also resistant against highly corrosive conditions.

We can supply graphite products for uses at temperatures from  $-250^{\circ}\text{C}$  to  $+1,000^{\circ}\text{C}$ .

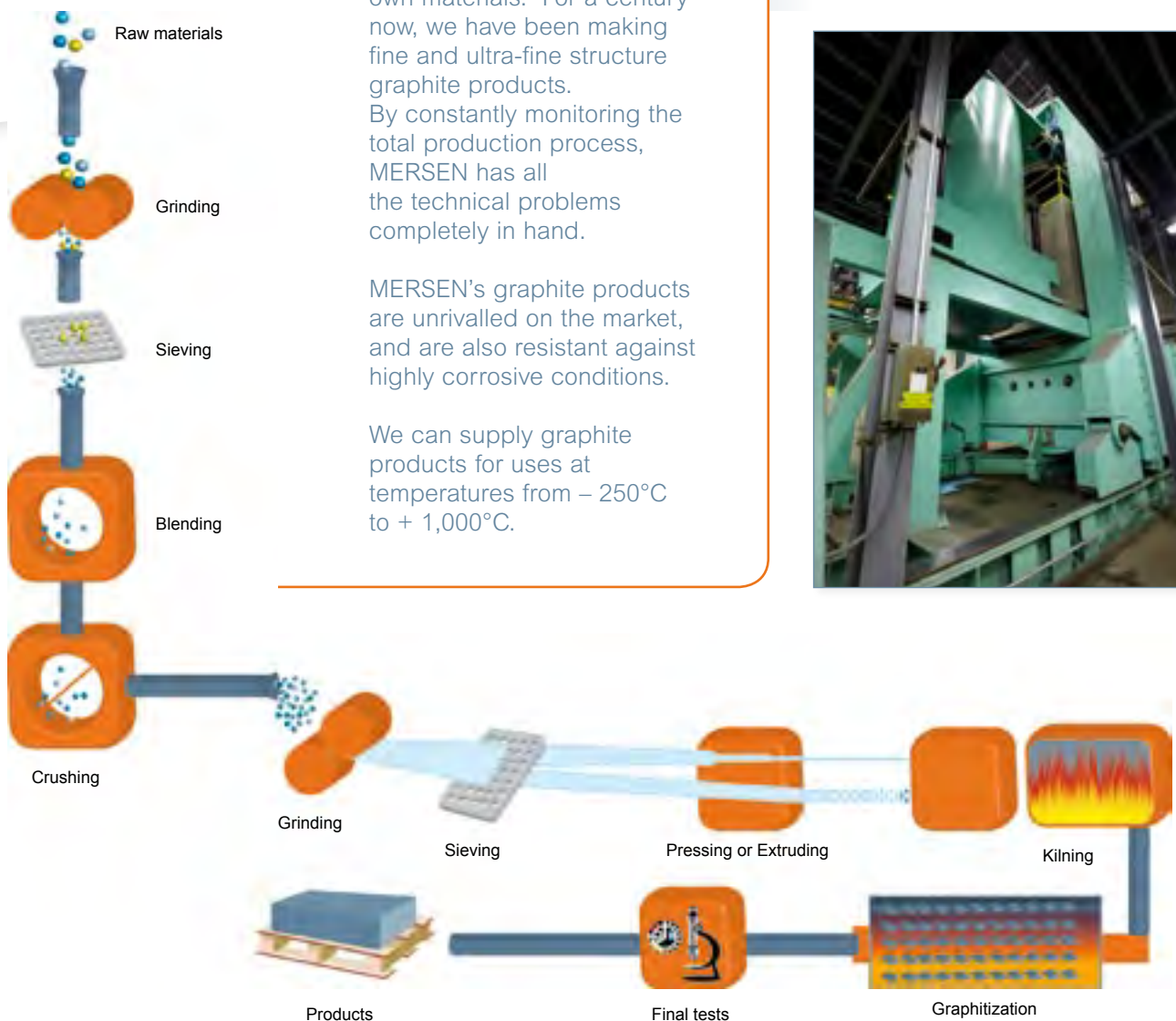

# APPLICATIONS FOR MERSEN CARBONS



- Inorganic chemistry
- Organic chemistry
- Metallurgy
- Fine chemistry and pharmaceuticals
- Environmental protection
- Food industry,...

## GRAPHITE PRODUCTS

MERSEN makes fine-grain and ultra-fine-grain graphites up to large size products. These technically mature products help improve the mechanical strength and resistance of chemical products considerably.

## LOW AND STABLE FRICTION COEFFICIENT

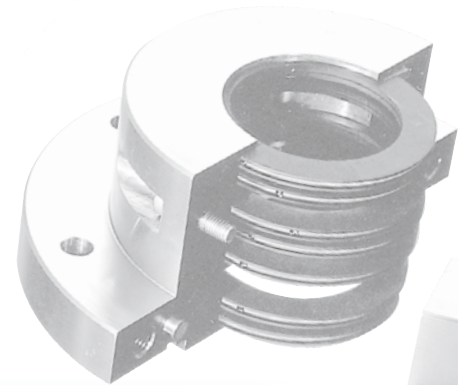
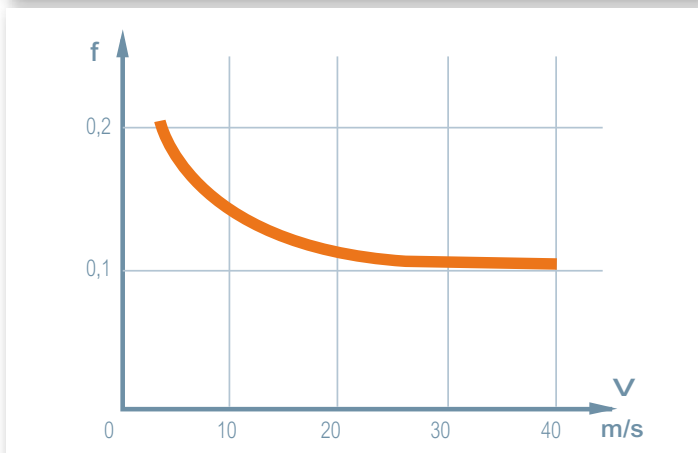
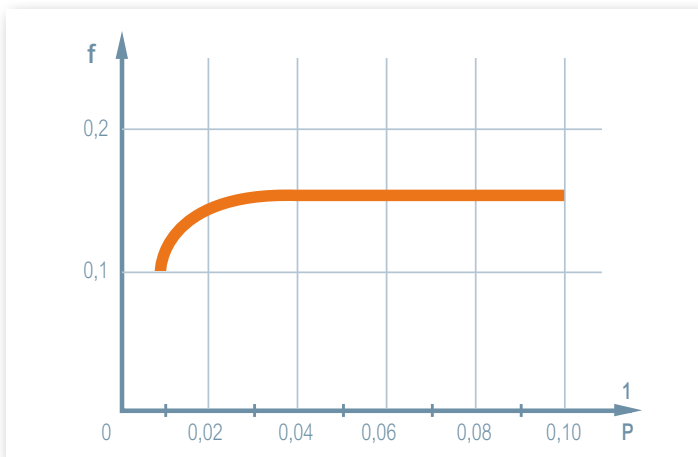

## GRAPHITE AS A MATERIAL

- Outstanding resistance to high temperatures
- Outstanding thermal and electrical conductivity
- Good adhesion
- Highly resistant to corrosion
- Chemically inert
- Lightweight

# SHAFT SEALS

## THE EXPERIENCE OF A LEADING ENTERPRISE



MERSEN's TURBOGRAF seal system is a labyrinth seal for rotating shafts to seal gases and vapours. If selected correctly, leaks can be reduced virtually to zero.

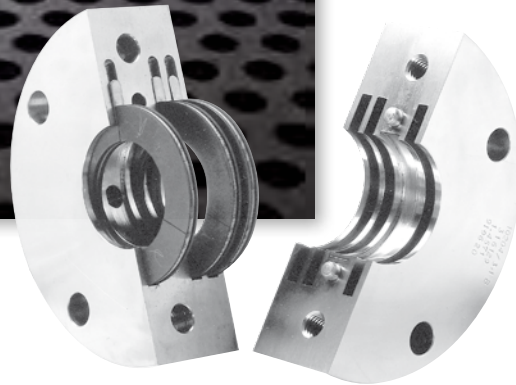

O-rings are available in split and non-split designs, with overlapping or radial section segments.

The right material for carbon rings or metal components is selected in the light of the design temperature and medium.

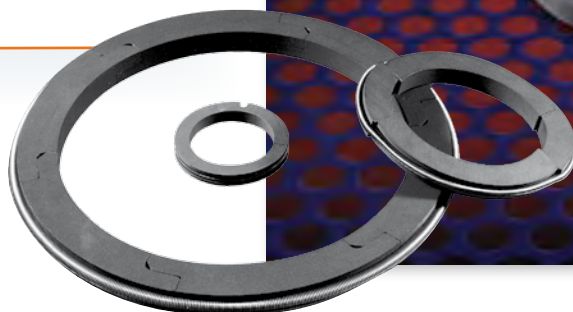

# PRODUCT SUMMARY

Series	Operating pressure per seal	Two part casing	Chamber design	O-rings		Connections		
				et	mt	S	A	F
<b>TGC 200</b>								
TGCS	$p_e \leq 20$ bar	•			•	•		•
TGCA	$p_e \leq 20$ bar	•			•		•	
TGCSA	$p_e \leq 20$ bar	•			•	•		•
TGCK	$p_e \leq 20$ bar	•			•			•
TGCT S	$p_e \leq 20$ bar	•			•	•		
TGCT F	$p_e \leq 20$ bar	•			•			•
<b>TGC 500</b>								
TGCA	$p_e \leq 3$ bar	•			•		•	
TGCK	$p_e \leq 3$ bar	•			•			
<b>TGA 300</b>								
TGA	$p_e \leq 0,5$ bar		•		•	(•)	(•)	(•)
<b>TGA 250</b>								
TGA	$p_e \leq 15$ bar		•		•	(•)	(•)	
<b>TGA 400</b>								
TGA	$p_e \leq 75$ bar		•		•	(•)	(•)	



## KEY

et : Single-part

mt : Multi-part

S : Barrier gas connection

F : Grease barrier, max.

Operating pressure  $p_e \leq 0,5$  bar

A : Extraction

(•) : Depending on design

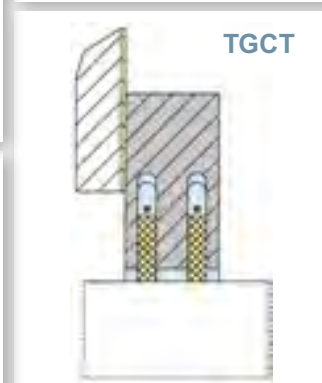
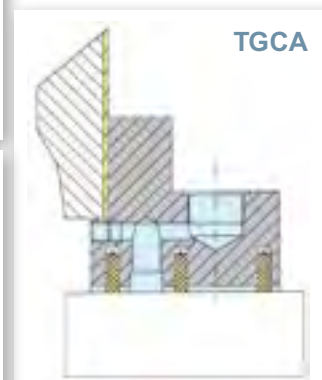
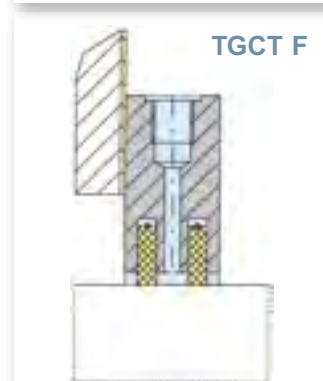
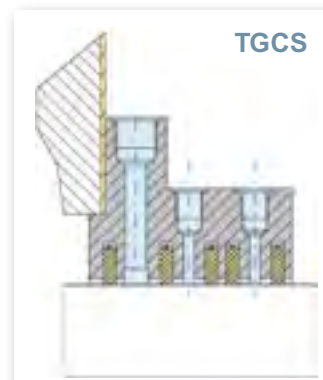

# TYPE TGC SHAFT SEALS

MERSEN's TURBOGRAF Type TGC shaft seals are made of high quality O-rings and split casings. The O-rings are three-section, radial split or overlapping joints, held together by springs.

The casing and O-ring materials can be modified to suit a wide range of working conditions. TGC series shaft seals are used in fans and ventilators: preferred ranges 0 – 40 bar and –150 to 600 °C.

Please complete and return the questionnaire to MERSEN so that we can design your seals to suit you.



## ZERO MAINTENANCE

With their split casing design, the O-rings (3 split) can be easily fitted or removed without disassembling the shaft.

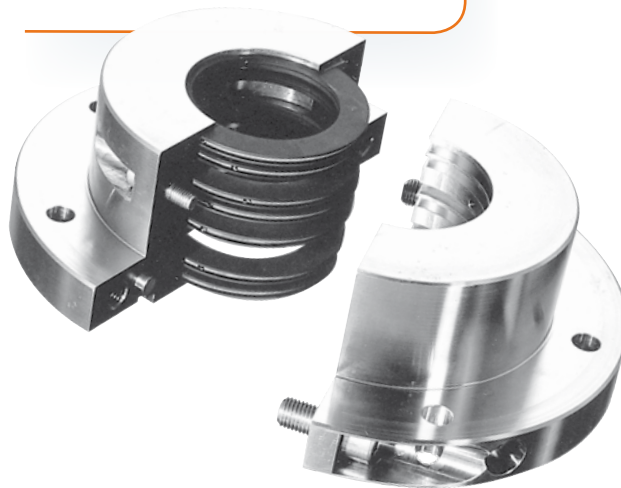

## MATERIALS:

Casing:  
Cast, steel (1.4021), galvanised steel, stainless steel (1.4571), Hastelloy (C4, C22, C276), titanium, Incone...

Spring and stops:  
Stainless steel: 1.4571, Hastelloy, Inconel

O-rings:  
Carbon  
The rings are three-way split.  
Radial cut or overlapping joint.



# TGC 200 SHAFT SEALS

CROSS-SPLIT CASINGS MULTI-PART  
O-RINGS RADIAL CUT

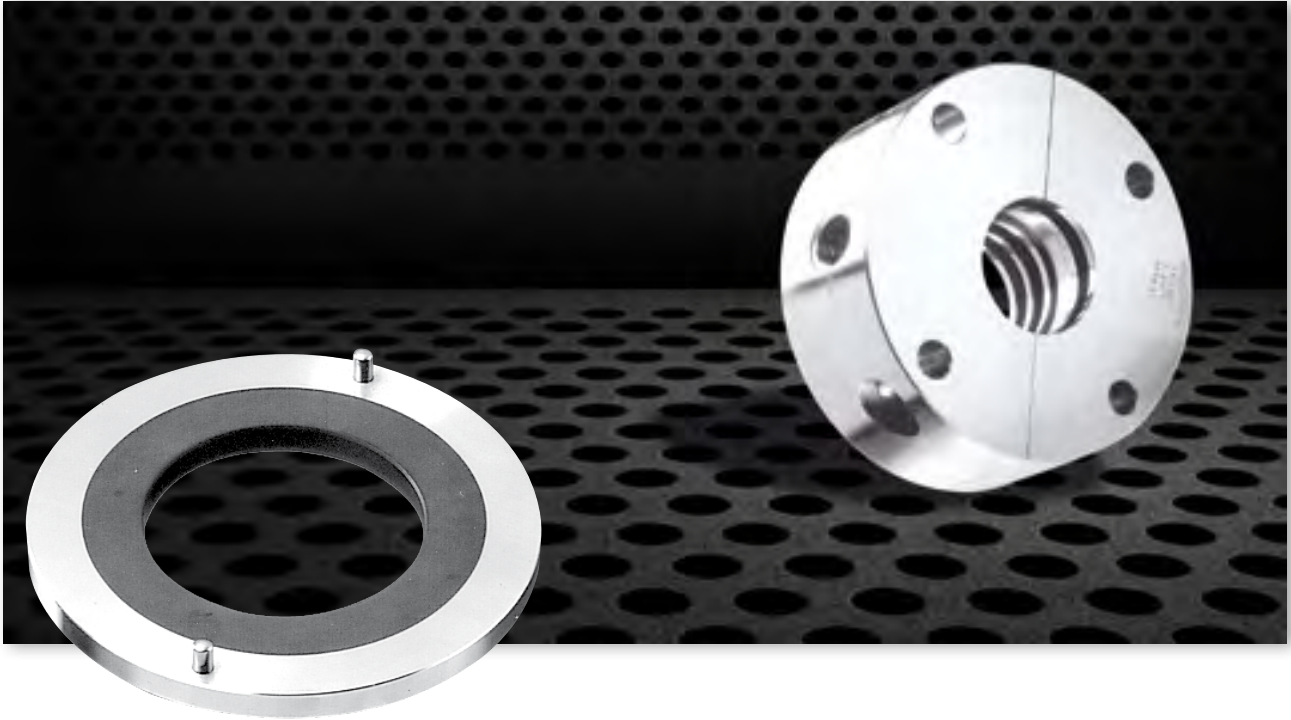

- **OPERATING PRESSURE:**  
0 – 30 bar
- **OPERATING TEMPERATURE:**  
- 150°C to 550°C
- **SPEED:**  
Up to 150 m/s
- **SHAFT DIAMETER:**  
30 to 450 mm





# TYPICAL APPLICATIONS

## TGC 200 SHAFT SEALS

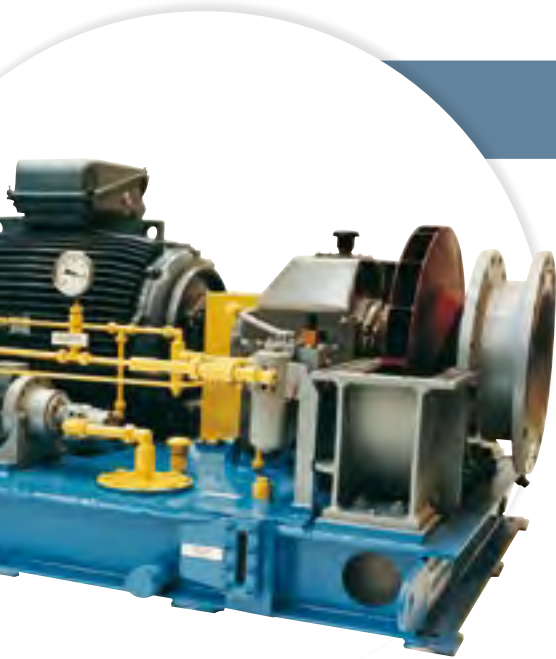

### TGCT

Short-form shaft seal. With barrier gas connection or grease barrier connection

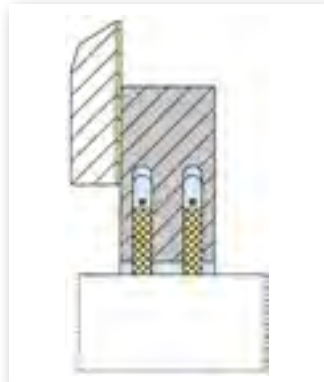

### TGCS

Shaft seal with barrier gas connection. Barrier gas pressure must be greater than working pressure.

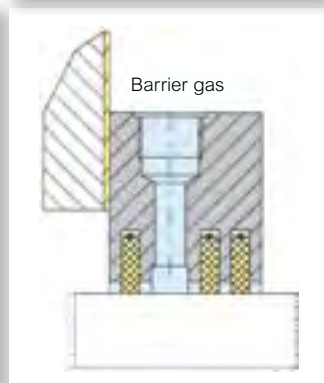
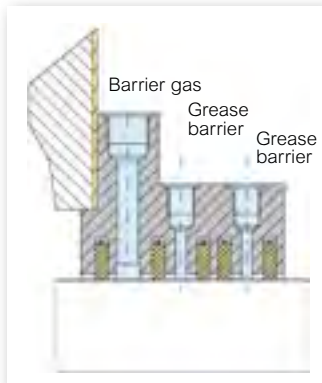

### TGCT S

With barrier gas.

### TGCA

Shaft seal and extractor.

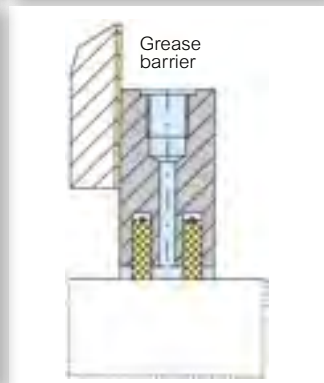
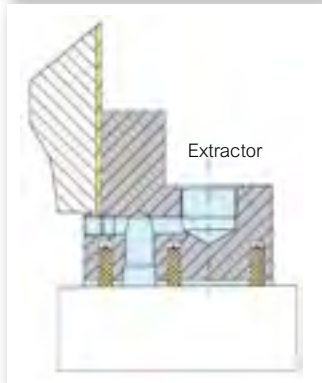

### TGCT F

With grease barrier.

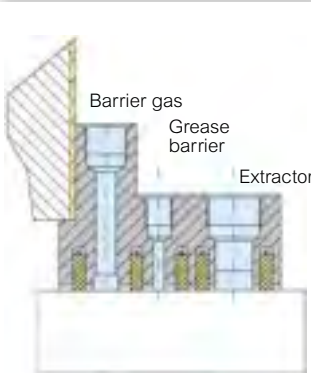

### TGCSA

Shaft seal with barrier gas connection and extractor.



# DIMENSIONS

## TYPE TGC 200 SHAFT SEALS

Shaft seal with barrier gas extractor and grease barrier connection (alternative).

O-rings three-part radial cut TYPE TGCT SHAFT SEALS.

### WITH BARRIER GAS CONNECTION

O-rings	Length
2 O-rings	40 mm
3 O-rings	50 mm
4 O-rings	60 mm
5 O-rings	70 mm
6 O-rings	80 mm

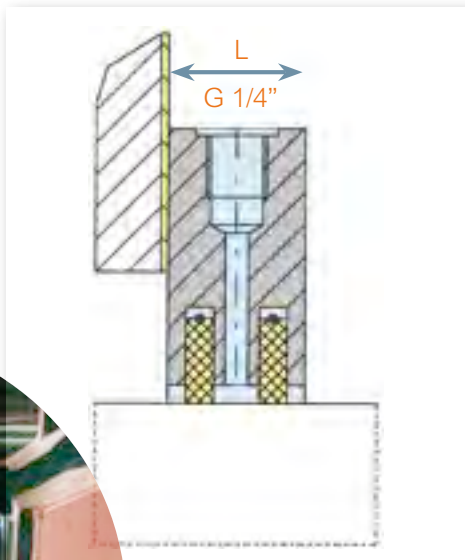
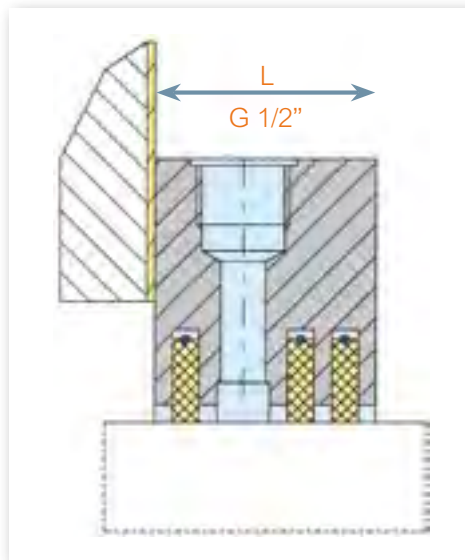

### WITH GREASE BARRIER CONNECTION

O-rings	Length
2 O-rings	30 mm
3 O-rings	40 mm
4 O-rings	50 mm
5 O-rings	60 mm
6 O-rings	70 mm

### TGCT WITHOUT BARRIER GAS OR GREASE BARRIER

O-rings	Length
2 O-rings	30 mm
3 O-rings	40 mm
4 O-rings	50 mm
5 O-rings	60 mm
6 O-rings	70 mm



# TYPE TGC 200 SHAFT CASING

## HOLE PATTERN

Shaft diameter up to 160 mm

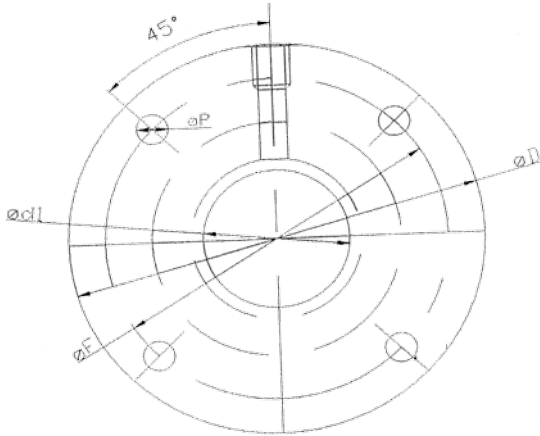

Shaft diameter 161 to 300 mm

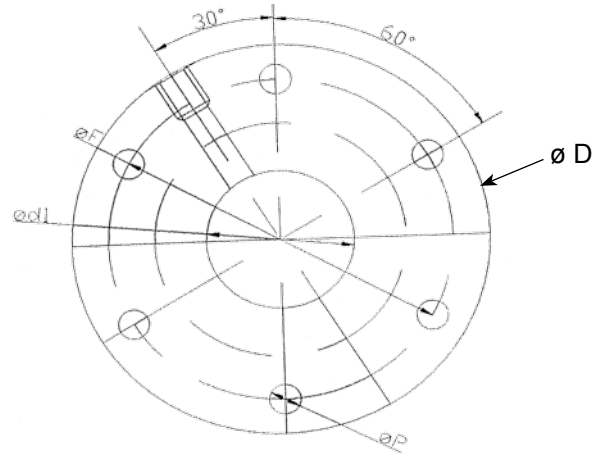

Average shaft d	$\varnothing D$	$\varnothing d1$	$\varnothing F$	Hole pattern	For bolt
30	150	40	120	4*15	M14
40	160	50	130	4*15	M14
50	170	60	140	4*15	M14
60	180	70	150	4*15	M14
70	190	80	160	4*15	M14
80	200	90	170	4*15	M14
90	210	100	180	4*15	M14
100	220	110	190	4*15	M14
110	230	120	200	4*15	M14
120	240	130	210	4*15	M14
130	250	140	220	4*15	M14
140	260	150	230	4*15	M14
150	270	160	240	4*15	M14
160	280	170	250	4*15	M14
170	290	180	260	6*15	M14
180	300	190	270	6*15	M14
190	310	200	280	6*15	M14
200	320	210	290	6*15	M14
250	370	260	340	6*15	M14
300	420	310	390	Special casing	
350	470	360	440	Special casing	
400	520	410	490	Special casing	
450	570	460	540	Special casing	



# TGC 500 SHAFT SEALS

## RINGS MULTI-PART AND OVERLAPPING



- **OPERATING PRESSURE:**  
0 to 5 bar
- **OPERATING TEMPERATURE:**  
-100 to 500°C
- **MAX. SPEED:**  
50 m/s
- **SHAFT DIAMETER:**  
40 to 340 mm
- **MATERIALS:**  
O-rings: Carbon, PTFE  
Springs and stops: Stainless steel, Hastelloy, titanium, Inconel  
Casings: stainless steel, steel, galvanised, steel, cast iron, Hastelloy, titanium, Inconel

SINGLE OVERLAP

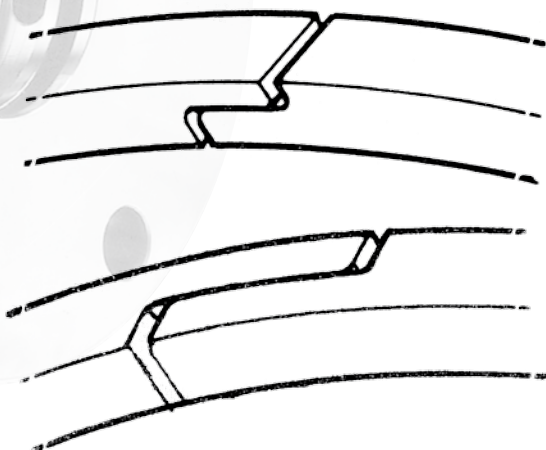

OVERLAPPING JOINT

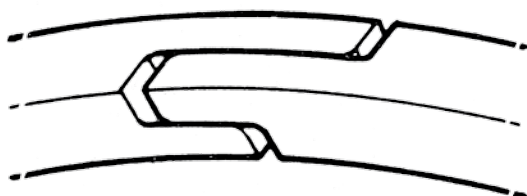

The three-section components are made with overlapping joint supports. The springs hold the O-rings constantly against the shaft, giving an outstanding seal, even at varying operating temperatures.

**Typical application:** The combination of radial cut O-rings on the medium side and overlapping O-rings on the bearing side gives a barrier gas flow tailored to the medium, and minimising leaks to atmosphere.

Please complete and return the questionnaire to MERSEN so that we can design your seals to suit you.

# DIMENSIONS

## TYPE TGCS – TGCA SHAFT SEALS

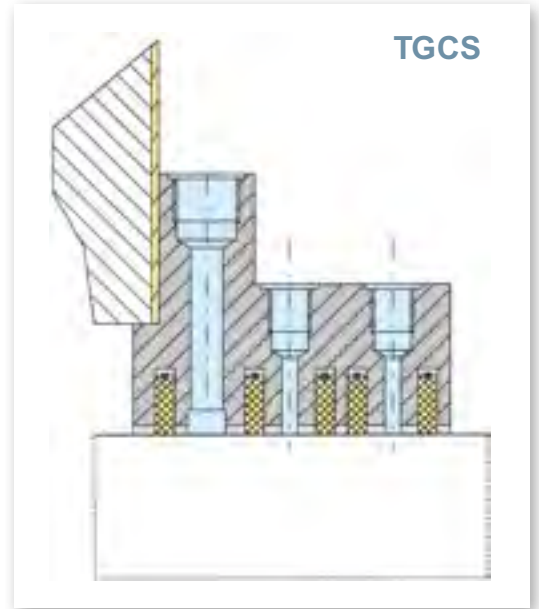
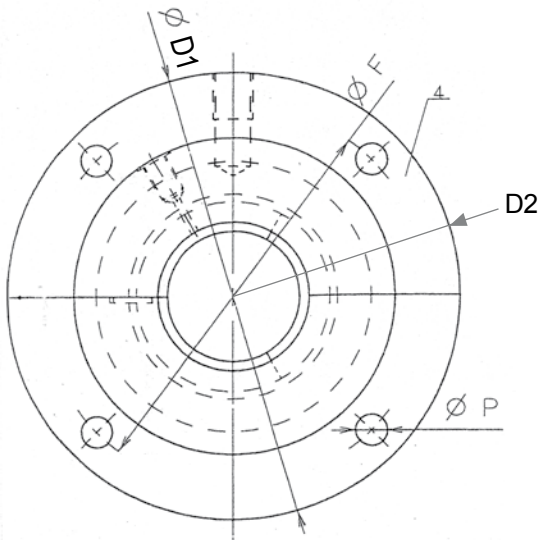

	Length	Barrier gas connection	Grease barrier connection
5 O-rings	95 mm	1/2"	1*1/4"
6 O-rings	103 mm	1/2"	1*1/4"
7 O-rings	113 mm	1/2"	1*1/4"
8 O-rings	127 mm	1/2"	2*1/4"
9 O-rings	137 mm	1/2"	2*1/4"
10 O-rings	147 mm	1/2"	2*1/4"
11 O-rings	157 mm	1/2"	2*1/4"
12 O-rings	167 mm	1/2"	2*1/4"



# SHAFT SEALS TYPE TGCS

## TGCA – TGCSA

RADIAL CUT SHAFT RINGS (TGC 200) OR  
OVERLAPPING JOINT (TGC 500)

Shaft	External diameter	Hole radius	Holes	D1	D2	For bolts
45	210	175	4x15	140	115	M14
50	220	185	4x15	150	125	M14
60	230	195	4x15	160	135	M14
70	240	205	4x15	170	145	M14
80	260	220	4x15	180	155	M14
90	270	230	4x15	190	165	M14
100	280	240	6x15	200	175	M14
110	290	250	6x15	210	185	M14
120	300	260	6x15	220	195	M14
130	310	270	6x15	230	205	M14
140	320	280	6x15	240	215	M14
150	330	290	6x15	250	225	M14
160	340	300	6x19	260	235	M18
170	350	310	6x19	270	245	M18
180	360	320	6x19	380	255	M18
190	370	330	6x19	290	265	M18
200	420	365	8x15	310	275	M18
220	440	385	8x15	330	295	M18
240	460	405	8x15	350	315	M18
260	480	425	8x19	370	335	M18
280	500	445	8x19	390	355	M18
300	520	465	8x19	410	375	M18
320	540	485	8x19	430	395	M18
340	560	505	8x19	450	415	M18



# SHAFT SEALS TYPE TGA

**MERSEN's TURBOGRAF type TGA shaft seals for rotating shafts. The carbon rings (single or multi-part) with overlapping or radially cut segments are arranged in chambers.**

O-rings can be made up individually to customers' specifications (chamber, grease barrier chamber, barrier gas chamber etc.).

The individual chambers are undivided rings, and are normally made of casting, steel or stainless steel. The O-rings are multi-part radial cut or overlapping joint. We regard using barrier gas as essential with toxic or highly aggressive media. The chamber sections have bores or slots for mounting bolts.

Please complete and return the questionnaire to MERSEN so that we can design your seals to suit you.



- **APPLICATIONS:** Fans, extractors, turbo-compressors, driers, water turbines
- **TYPE TGA 300**  
O-rings are split and easy to fit
- **OPERATING PRESSURE PER SEAL:** Max. 40 bar
- **OPERATING TEMPERATURE:** up to 650 °C
- **SPEED:** up to 150 m/s
- **MATERIALS:**  
Chamber sections: stainless steel, galvanised steel, cast, aluminium, Hastelloy, titanium, Inconel  
Springs: stainless steel, astelloy, titanium, Inconel  
O-rings: carbon, PTFE

# TGA 250

## WITH CASING AND COVER

TGA 250 seals with casings and covers are designed as modular systems. They can be assembled.

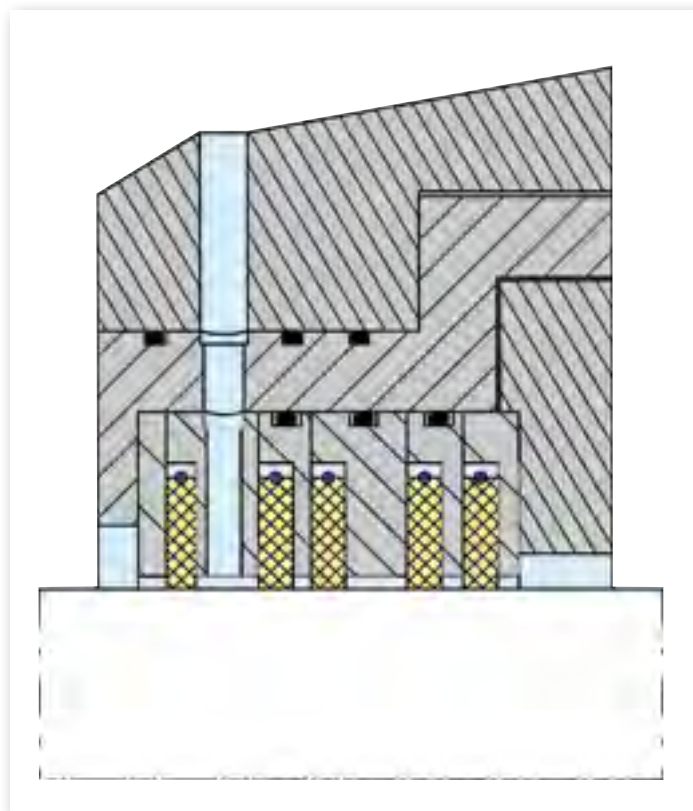

- **OPERATING PRESSURE:**  
10 bar/O-ring  
Up to 60 bar  
(operating pressure)
- **OPERATING TEMPERATURE:**  
Up to 400 °C
- **SPEED:**  
Up to 150 m/s
- **SHAFT DIAMETER:**  
20 – 400 mm
- **CHAMBER SECTIONS:**  
Monobloc design
- **MATERIALS:**  
Chamber and casing: stainless steel, galvanised steel, cast iron, aluminium, Hastelloy, titanium, Inconel  
Springs: stainless steel, Hastelloy, titanium, Inconel  
O-rings: Carbon, O-rings triple-split radial cut

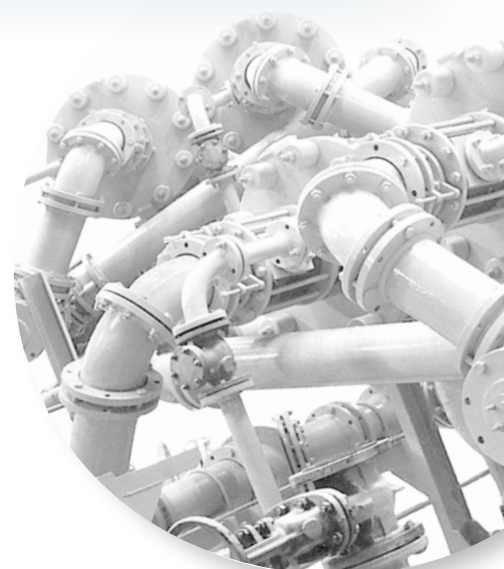



# TGA 300

## MODULAR DESIGN

Thanks to their modular design, TGA 300 shaft seals can be used in multiples depending on the conditions.

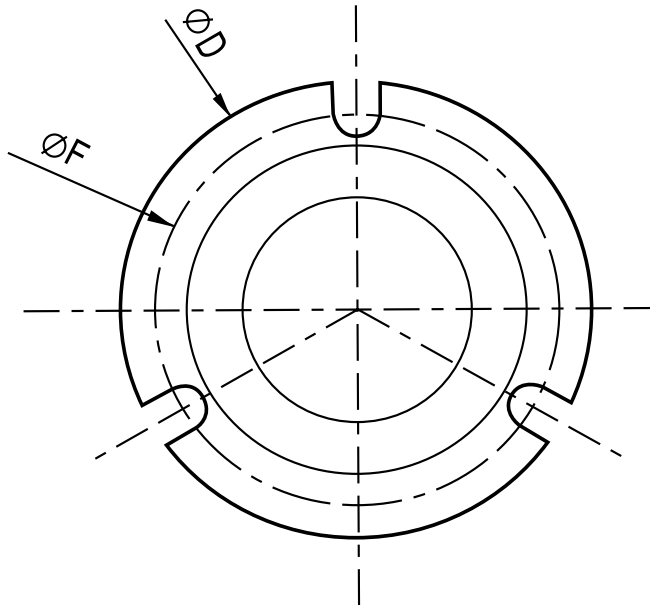

## TYPICAL INSTALLATION:

TGA 300

### TGA - S

With barrier gas shaft seal with barrier gas chamber.  
Barrier gas pressure must be greater than medium pressure.

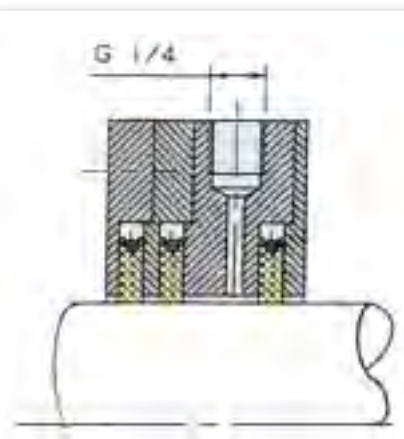
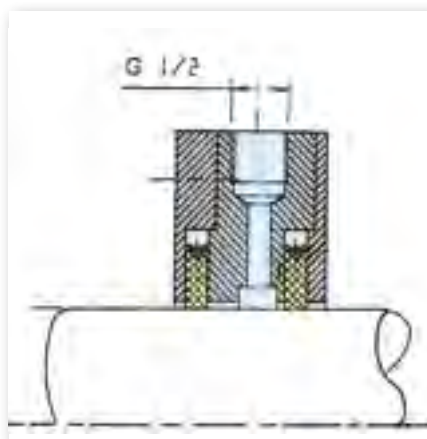

### TGA - F

Shaft seal with grease barrier chamber.

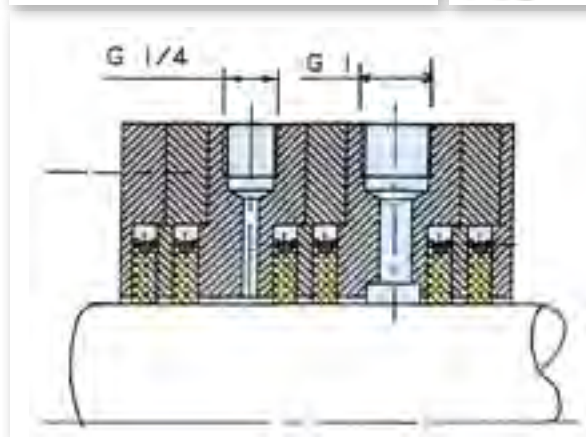

### TGA - SA

shaft seal with barrier gas chamber and extraction chamber.

# DIMENSIONS

## TGA 300

Shaft	External diameter	Hole radius	Holes
20	95	75	10
25	100	80	10
30	105	85	10
35	110	90	10
40	115	95	10
45	130	105	12
50	140	115	12
55	145	120	12
60	150	125	12
65	155	130	12
70	160	135	12
75	165	140	12
80	170	145	12
85	175	150	12
90	180	155	12
95	185	160	12
100	190	165	12
105	195	170	12
110	200	175	12



With barrier gas G 1/2 "

Type	Rings	Length
TGA 1 S 1	2	56
TGA 1 S 2	3	66
TGA 1 S 3	4	76
TGA 1 S 4	5	86
TGA 1 S 5	6	96

With grease barrier G 1/4 "

Type	Rings	Length
TGA 1 F 1	2	39
TGA 1 F 2	3	49
TGA 1 F 3	4	59
TGA 1 F 4	5	69
TGA 1 F 5	6	79

Without barrier gas and grease barrier

Type	Rings	Length
TGA 1	2	18
TGA 2	3	28
TGA 3	4	38
TGA 4	5	48
TGA 5	6	58



# TYPE TGA 2000

## O-rings designed for high differential pressures.

The ring consists of a carbon ring and housing, the carbon ring being shrink-fitted into the housing.

With its modular design, the TGA 2000 shaft seal can be used in multiples depending on conditions involved.

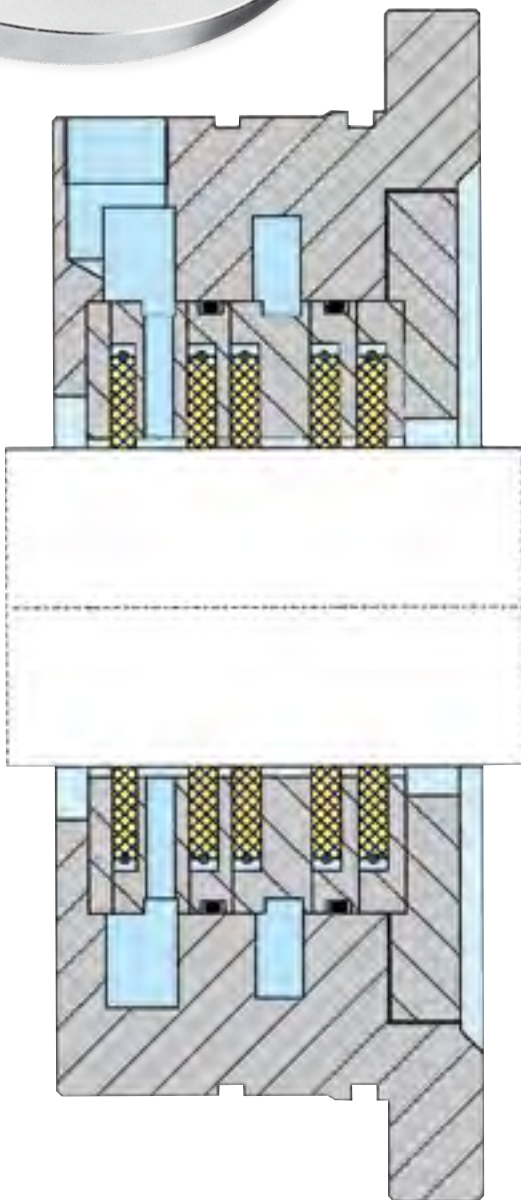
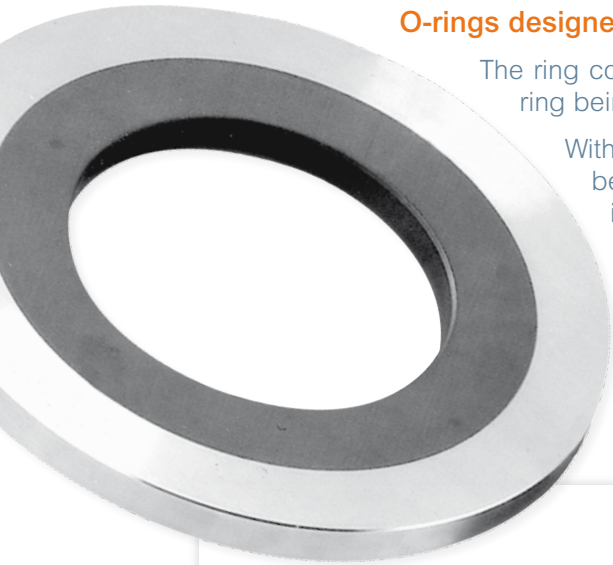

- **OPERATING PRESSURE:**  
100 bar  
20 bar / O-ring
- **OPERATING TEMPERATURE:**  
300 °C
- **SHAFT DIAMETER:**  
20 to 150 mm
- **SLIDING SPEED:**  
Up to 150 m/s
- **MATERIALS:**  
Casing: stainless steel,  
galvanised steel, Hastelloy  
O-ring: graphite with tyre,  
carbon or electro-graphite  
Tyre: stainless steel (1.4571)  
or titanium

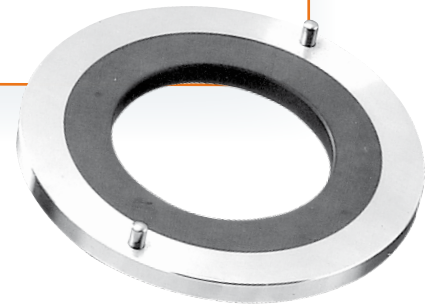

# SHAFT SLEEVES



The life expectancy and efficiency of our shaft seals depends mainly on precision manufactured shaft sleeves and coatings, which protect against wear.

We make our shaft sleeves to your specifications.

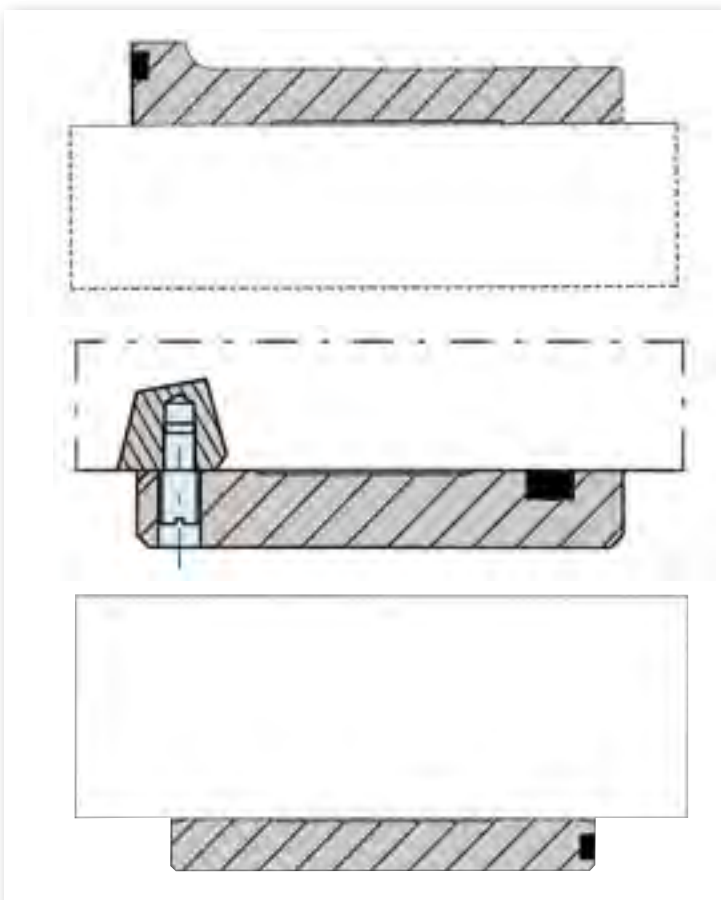

# ASSEMBLY AND OPERATING INSTRUCTIONS

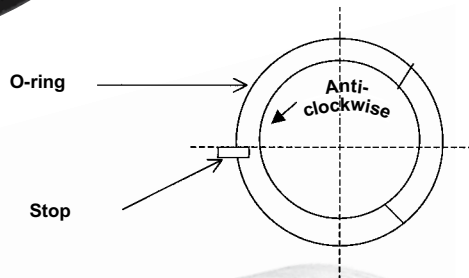

## SHAFT SEALS TYPE TGC

1. Check shaft or shaft sleeve.
2. Shaft must be crack-free and ground to fit.
3. Insert O-ring (or POPYEX® seals)
4. Fit O-ring to shaft, one segment at a time, and lock in place with spring.

### NOTE:

Observe shaft direction of rotation (type TGC).

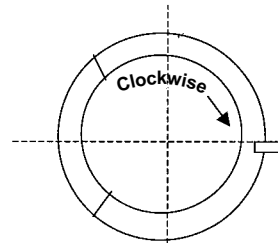

The stops must be inserted as stated below:

5. Fit lower casing half to shaft from underneath and fit or bolt in position.
6. Once all O-rings in place, fit upper casing half.
7. Connect housing halves.

### NOTE:

Remove O-rings and inspect annually. Replace O-rings if play is excessive.

## INSTALLATION AND OPERATING INSTRUCTIONS SHAFT SEALS TYPE TGA

1. Check shaft or shaft sleeve.
2. Polish shaft. Check dimensions and surface quality.
3. Insert O-ring (or POPYEX® seals).
4. Insert chambers and O-rings in packing space (type TGA). Chamber stops must engage with the side holes in the O-rings.
5. Align shaft seal with shaft and bolt to fan wall.

Data herein contained are provided for general information purpose only and are not binding. MERSEN shall have no liability whatsoever with respect to information contained herein. Duplication, reproduction or translation of any information contained herein, in whole or in part, is strictly prohibited without prior written consent of MERSEN. Our materials are in conformity with the RoHS-Directive (Restriction of the use of certain Hazardous Substances in electrical and electronic equipment). Besides MERSEN guarantees the application of the European Community REACH-Regulation (Registration, Evaluation, Authorization and Restriction of Chemical substances) to all its plants located in Europe.



Архангельск (8182)63-90-72  
 Астана (7172)727-132  
 Астрахань (8512)99-46-04  
 Барнаул (3852)73-04-60  
 Белгород (4722)40-23-64  
 Брянск (4832)59-03-52  
 Владивосток (423)249-28-31  
 Волгоград (844)278-03-48  
 Вологда (8172)26-41-59  
 Воронеж (473)204-51-73  
 Екатеринбург (343)384-55-89  
 Иваново (4932)77-34-06

Ижевск (3412)26-03-58  
 Иркутск (395)279-98-46  
 Казань (843)206-01-48  
 Калининград (4012)72-03-81  
 Калуга (4842)92-23-67  
 Кемерово (3842)65-04-62  
 Киров (8332)68-02-04  
 Краснодар (861)203-40-90  
 Красноярск (391)204-63-61  
 Курск (4712)77-13-04  
 Липецк (4742)52-20-81

Магнитогорск (3519)55-03-13  
 Москва (495)268-04-70  
 Мурманск (8152)59-64-93  
 Набережные Челны (8552)20-53-41  
 Нижний Новгород (831)429-08-12  
 Новокузнецк (3843)20-46-81  
 Новосибирск (383)227-86-73  
 Омск (3812)21-46-40  
 Орел (4862)44-53-42  
 Оренбург (3532)37-68-04  
 Пенза (8412)22-31-16

Пермь (342)205-81-47  
 Ростов-на-Дону (863)308-18-15  
 Рязань (4912)46-61-64  
 Самара (846)206-03-16  
 Санкт-Петербург (812)309-46-40  
 Саратов (845)249-38-78  
 Севастополь (8692)22-31-93  
 Симферополь (3652)67-13-56  
 Смоленск (4812)29-41-54  
 Сочи (862)225-72-31  
 Ставрополь (8652)20-65-13

Сургут (3462)77-98-35  
 Тверь (4822)63-31-35  
 Томск (3822)98-41-53  
 Тула (4872)74-02-29  
 Тюмень (3452)66-21-18  
 Ульяновск (8422)24-23-59  
 Уфа (347)229-48-12  
 Хабаровск (4212)92-98-04  
 Челябинск (351)202-03-61  
 Череповец (8202)49-02-64  
 Ярославль (4852)69-52-93

Киргизия (996)312-96-26-47

Россия (495)268-04-70

Казахстан (772)734-952-31